

Data sheet

Actuators for modulating control

AME 25 SD - safety function (spring down)

AME 25 SU - safety function (spring up)

Description



AME 25 SD or SU electric actuators are used with valves gen.2009 type VRB, VRG, VF, VL with additional adapter (Code No. 065Z0311, not supplied) and VFS 2 valves up to DN 50 diameter.

The actuator automatically adapts its stroke to valve end positions which reduces commissioning time.

The actuator has some special features:

- The advanced design incorporates load related 'switch-off' to ensure that actuators and valves are not exposed to overload;
- The advanced design incorporates a diagnostic LED, operational data capture and self stroking feature;
- Low weight and robust;
- Safety function versions:
 - SD (spring down)
 - SU (spring up).

Main data:

- Nominal voltage:
 - 24 VAC, 50 Hz/60 Hz
- Control input signal:
 - 0(4)...20 mA
 - 0(2) ... 10 V
- Force: 450 N
- Stroke: 15 mm
- Speed: 15 s/mm
- Max. medium temperature: 150 °C
- Self stroking
- Output signal

Ordering

Actuator

Type	Supply voltage	Code No.
AME 25 SD (spring down)	24 V~	082H3038
AME 25 SU (spring up)	24 V~	082H3041

Accessories

Type	Code No.
Adapter for VFS 2 valve DN 15-50 (for media temp. over 150 °C)	065Z7548
Adapter for VRB/VRG/VF/VL valves (gen.2009) DN 15-50	065Z0311*
Stem heater for VFS valve DN 15-50	065B2171
Clutch AMV(E) 25, AMV(E) 35	003G6396

* Need to be ordered separately.

Technical data

Power supply	V	24 AC ±10 %
Power consumption	VA	14
Frequency	Hz	50/60
Control input Y	V	0-10 (2-10) Ri = 24 kΩ
	mA	0-20 (4 -20) Ri = 500 Ω
Output signal X	V	0-10 (2-10)
Closing force	N	450
Max. stroke	mm	15
Speed	s/mm	15
Max. medium temperature	°C	150 (200 - for VFS valve with adapter)
Ambient temperature		0 ... 55
Storage and transport temp.		-40 ... 70
Grade of enclosure		IP 54
Weight	kg	2,3
- marking in accordance with standards		Low Voltage Directive 73/23/EEC, EMC-Directive 2004/108/EEC: EN 60730-1, EN 60730-2-14

Safety function

The safety function will fully open or close the valve by power failure, depending upon the chosen safety action (SD/SU).
 Valve selection will also affect the safety action. The safety function unit is factory fitted to the rear of the actuator.

• not in accordance to DIN EN 14597

Valve type	Spring action selection will	
	Close port A-AB	Open port A-AB
VRG, VRB	SU	SD
VL (DN 15-50)	SU	SD
VF (DN 15-50)	SU	SD
VFS 2 (DN 15-50)	SD	SU

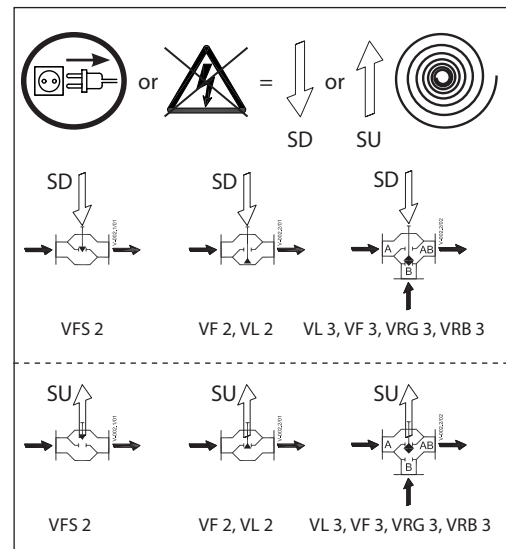

Safety function activation (AME 25 SD only)

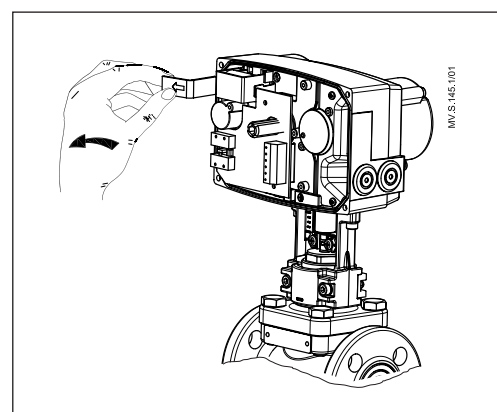

Disposal

The actuator must be dismantled and the elements sorted into various material groups before disposal.

Installation

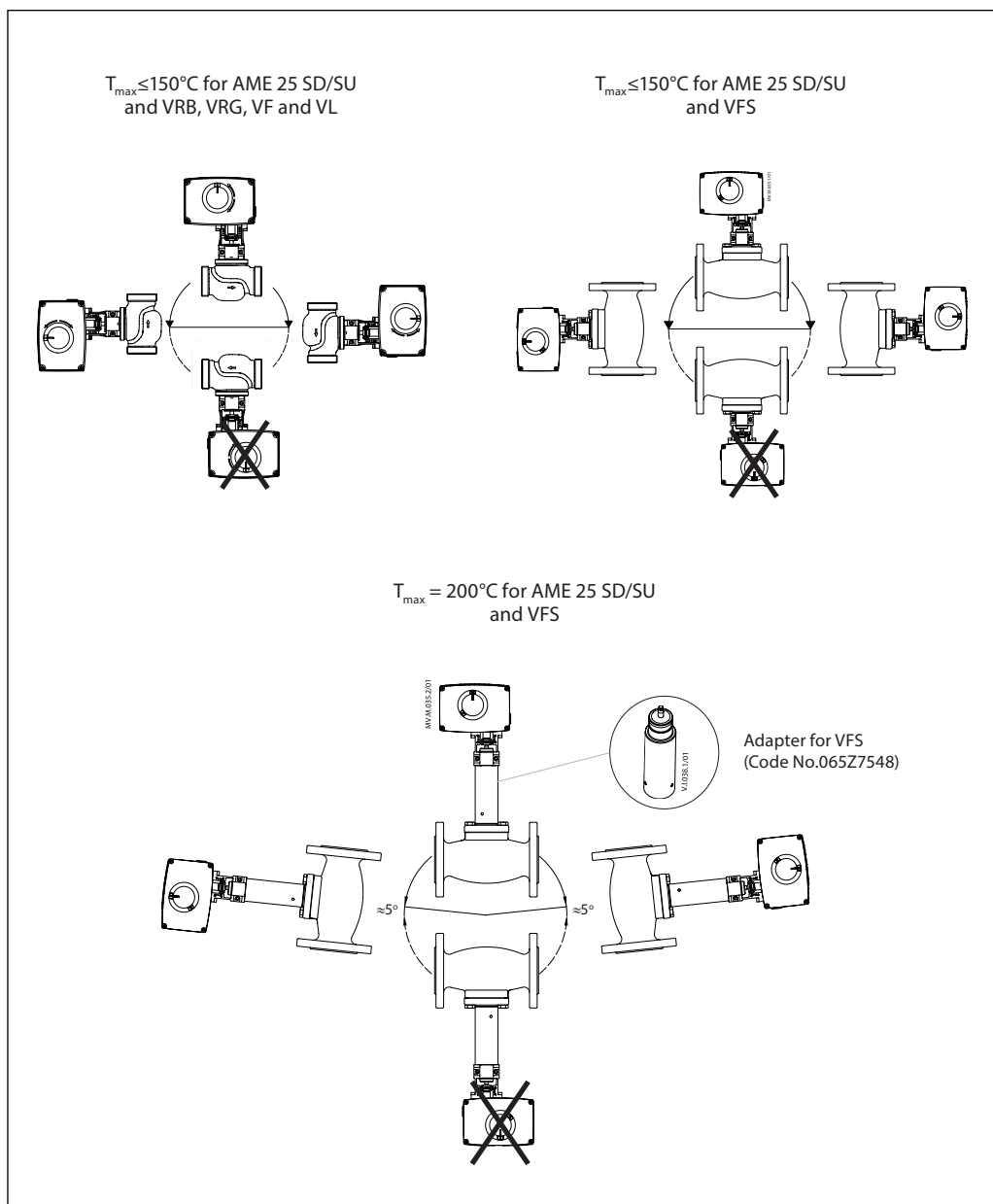

Mechanical

Use 4 mm Allan key (not part of actuator delivery) to mount actuator on the valve. Installation of the valve with the actuator is allowed in horizontal position or upwards. Installation downwards is not allowed.

The actuator must not be installed in an explosive atmosphere, at ambient temperature lower than 0 °C or at ambient temperature higher than 55 °C. It must not be subject to steam jets, water jets or dripping liquid as well.

Note: the actuator may be rotated up to 360° with respect to the valve stem by loosening the retaining fixture. Once the actuator is placed, retighten the fixture.

Electrical

Electrical connections can be accessed by removing the actuator cover. Two cable gland entries with thread (M20 x 1.5 and M16 x 1.5) are prepared for cable glands.

Note: Cable and cable gland used must not compromise the actuator's IP rating, and must ensure the connectors are fully strain relieved. Please observe local rules and regulations as well.

DIP switch setting

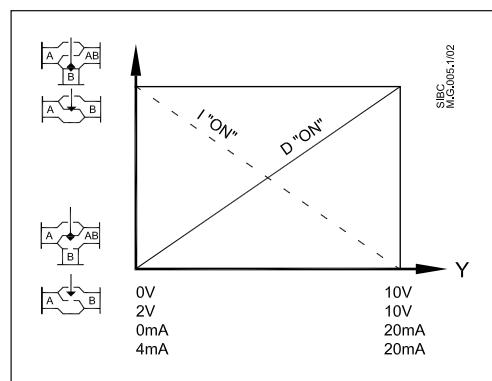
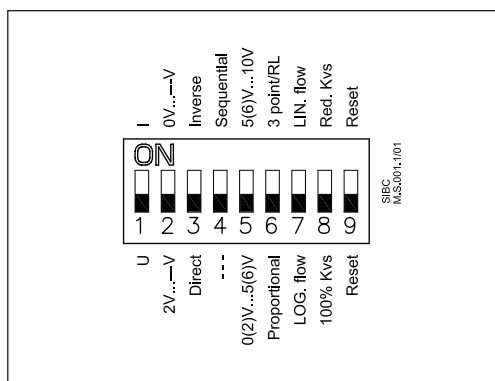

The actuator has a function selection DIP switch under the removable cover. In particular, if SW6 is set to ON, the actuator will perform as 3-point actuator.

The switch provides the following functions:

• **SW1: U/I - Input signal type selector:**

If set to OFF position, voltage input is selected. If set to ON position, current input is selected.

• **SW2: 0/2 - Input signal range selector:**

If set to OFF position, the input signal is in the range from 2-10 V (voltage input) or from 4-20 mA (current input). If set to ON position, the input signal is in the range from 0-10 V (voltage input) or from 0-20 mA (current input).

• **SW3: D/I - Direct or inverse acting selector:**

If set to OFF position, the actuator is direct acting (stem lowers as voltage increases). If actuator is set to ON position the actuator is inverse acting (stem raises as voltage increases).

• **SW4: —/Seq - Input signal range in sequential mode:**

If set to OFF position, the actuator is working in range 0(2)-10 V or 0(4)-20 mA. If set to ON position, the actuator is working in sequential range; 0(2)-5(6) V or 0(4)-10(12) mA or 5(6)-10 V or 10(12)-20 mA).

• **SW5: 0-5V/5-10V - Normal or sequential mode selector:**

If set to OFF position, the actuator is working in sequential range 0(2)-5 (6) V or 0(4)-10(12) mA. If set to ON position, the actuator is working in sequential range; 5(6)-10 V or 10(12)-20 mA.

• **SW6: Prop./3-pnt - Modulating or 3-point mode selector:**

If set to OFF position, the actuator is working normally according to control signal. If set to ON position, the actuator is working as 3-point actuator.

• **SW7: LOG/LIN - Equal percentage or linear flow through valve selector ¹⁾:**

If set to OFF position, the flow through valve is equal percentage. If set to ON position, the flow through valve is linear according to control signal.

• **SW8: 100% k_{VS} /Reduced k_{VS} - Flow reduction through valve selector ¹⁾:**

If set to OFF position, the flow through valve is not reduced. If set to ON position, the flow through valve is reduced by half of increment between standard K_{VS} values. Example: valve with K_{VS} 16 and SW8 set to ON – maximum flow through the valve is K_{VS} 13 (middle between standard K_{VS} 16 and next lower standard K_{VS} 10).

¹⁾ **NOTE:** To be used only in combination with valves with equal percentage characteristic.

• **SW9: Reset:**

Changing this switch position will cause the actuator to go through a self stroking cycle.

Wiring



24 V AC

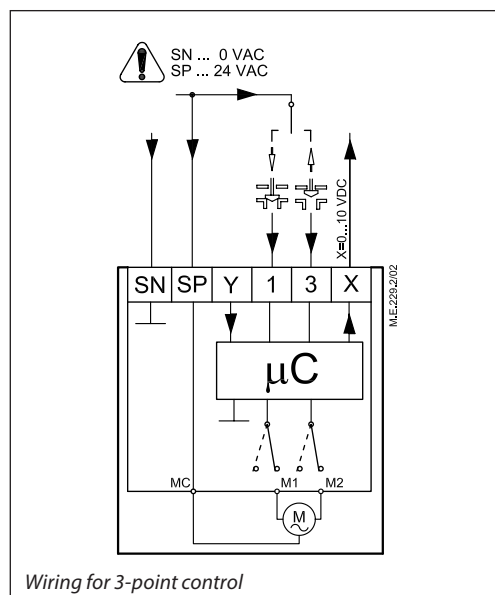
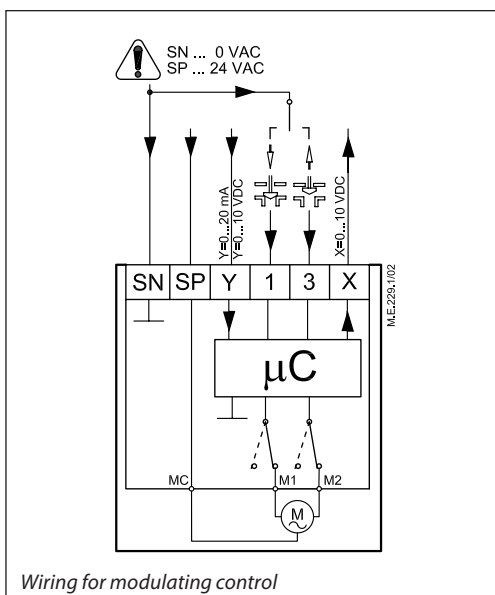

Automatic self stroking feature

When power is first applied, the actuator will automatically adjust to the length of the valve stroke. Subsequently, the self stroking feature can be re-initialised by changing position of SW9.

Diagnostic LED

The red diagnostic LED is located on the pcb under the cover. It provides indication of three operational states:

- Actuator Healthy (Permanently ON),
- Self Stroking (Flashes once per second),
- Error (Flashes 3 times per second - seek technical assistance).

Wiring length	Recommended square of the wiring
0-50 m	0,75 mm ²
> 50 m	1,5 mm ²

SP	24 V ACPower supply
SN	0 V Common
Y	0-10 V Input signal
	(2-10 V)	
	0-20 mA	
	(4-20 mA)	
X	0-10 VOutput signal
	(2-10 V)	

Commissioning

Complete the mechanical and electrical installation and perform the necessary checks and tests:

- Isolate control medium. (e.g. self stroking in a steam application without suitable mechanical isolation could cause a hazard).
- Apply the power. Note that the actuator will now perform the self stroking function.
- Apply the appropriate control signal and check the valve stem direction is correct for the application.
- Ensure that the actuator drives the valve over its full stroke, by applying the appropriate control signal. This action will set the valve stroke length.

The unit is now fully commissioned.

Commissioning / testing feature

The actuator can be driven to the fully open or closed positions (depending on valve type) by connecting SN to terminals 1 or 3.

Manual override

Manual override is done by means of positioning spindle inside the actuator:

- Disconnect power signal
- Remove the actuator cover
- Insert 5 mm Allan key (not part of actuator delivery) into the top of the positioning spindle
- Turn the key against the spring (observe the rotation direction)

To hold a manual override position, the key must be wedged.

After manual override is not needed:

- Restore power signal.

If manual override has been used then X and Y signal are not correct until the actuator reaches its end position. If this is not accepted reset the actuator, or apply accessory active return kit.

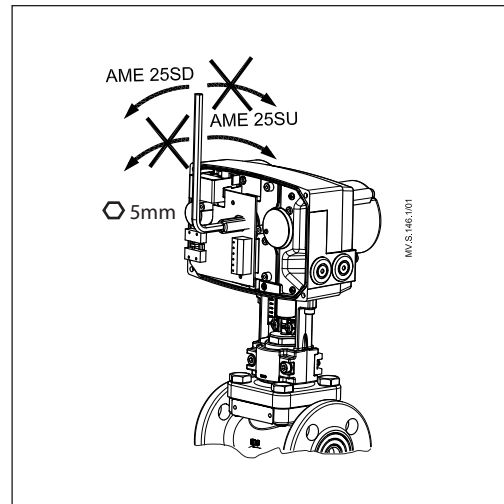

Actuator - valve combinations

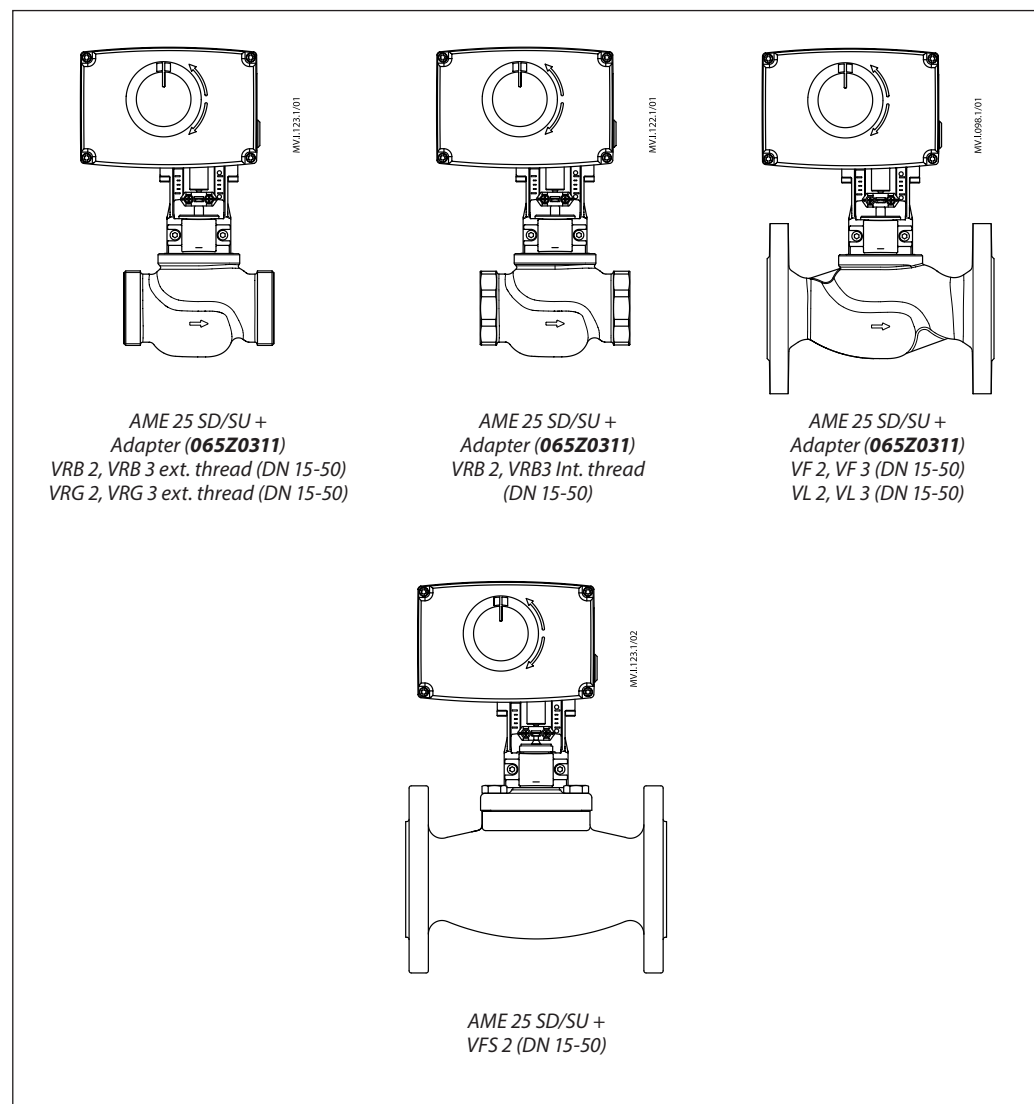

Dimensions

